

# ATLAS

## Material Handler 400MH

FAST. RELIABLE. VERSATILE.

# 400MH



-  40 - 41 t
-  175 kW (238 hp)
-  13.5 - 18.1 m



## Technical Information

### ENGINE

Power according to ISO 14396 .....	175 kW (238 HP)
RPM.....	1900/min
Make.....	Deutz TCD 6.1 L6 (Stage 3B)
Design.....	Turbocharger / intercooler
Cylinder capacity.....	6000 cm <sup>3</sup>
Number of cylinders.....	6
Borehole/lift.....	101 / 126
Cooling system.....	Water-cooled
Air filter.....	Dry air filter
Battery.....	2 x 12 V / 100 Ah
Alternator.....	24 V / 55 Ah
Starter.....	24 V / 4,8 kW

### HYDRAULIC SYSTEM

- AWE 4 System (Load Sensing)
- Load-limit-controlled high-perform. piston pumps
- Fuel-efficient required power regulation
- Primary and secondary protection against overload
- Suction valves for all work functions
- Load-retaining and fine-drop valve in lifting circuit
- Pipe-break protection valves for lifting cylinders
- Grab and grab-rotating function
- 2 additional circuits for add. consumer loads possible
- Temperature-controlled fan for cooler
- Max. oil flow.....640 l/min
- Max. operating pressure.....380 bar

### TRACTION DRIVE AND BRAKES

- Variable displacement motor
- 2-gear transmission
- Double-acting brake valve
- Driving direction pre-selection via lever at steering-wheel
- Maximum speed.....16 km/h
- Terrain speed.....5 km/h
- Crawling speed.....1 km/h
- All-wheel drive
- Dual circuit brake system.....Drum
- Parking brake.....Spring-loaded brake

### SWING ASSEMBLY

- Swing motor: Axial piston motor with priority valve
- Swing gear: Planetary transmission
- Swing brakes: Multidisc brake via pedal
- Max. swing speed.....8,5/min
- Swing torque.....93,4 kNm

### UNDERCARRIAGE

- 70 t special excavator axles
- Steering axle with auto. oscillating axle blocking
- 8 rubber tyres.....12.00 - 24 Superelastic

### FILL CAPACITIES

- Fuel tank.....425 Liter
- Cooling system.....48 Liter
- Engine oil.....15,5 Liter
- Hydraulic tank.....505 Liter
- Hydraulics system.....970 Liter

### DRIVER'S CAB

- Meets latest safety standards
- Extra-wide entrance
- Spacious leg room
- Excellent circumferential visibility
- Preparation for radio installation

### ATTACHMENTS

- Clamshell grab
- Orange peel grab
- Load hook
- Load lifting magnet
- Log grab

### EQUIPMENT

- Loading boom 10,60 m (C84.7i)
- Stick 7,70 m (D84.17i)
- Cab:**
- Air conditioning
- Slim steering column, height and tilt adjustable
- Seat adjustable separately from console

Work areas Loading boom 10,60 m (C84.7i) and Stick 7,70 m (D84.17i)

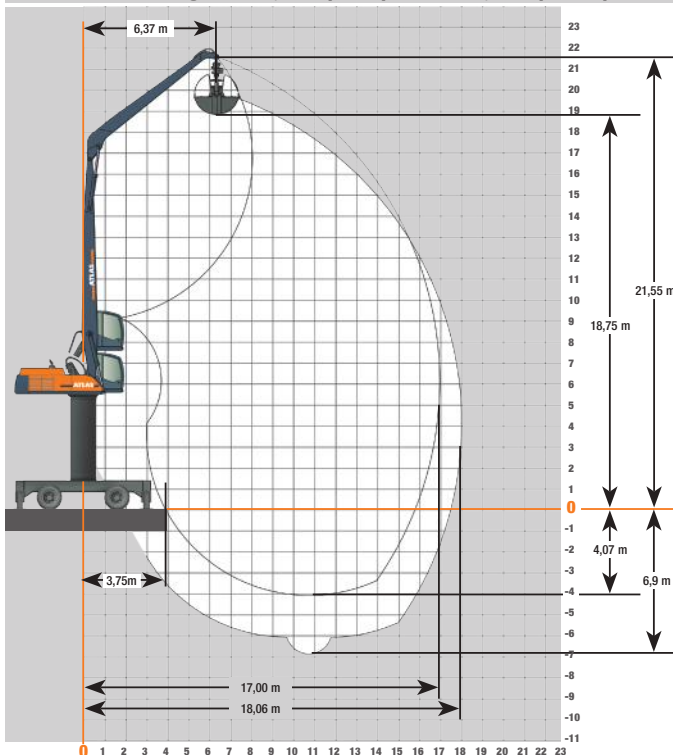

Lifting Capacities Loading boom 10,60 m (C84.7i) and Stick 7,70 m (D84.17i)

HEIGHT		Lifting Capacities, Loading boom 10,60 m (C84.7i) with Stick 7,70 m (D84.17i). Max. reach 17,0 m									
		4,5 m		7,5 m		10,5 m		13,5 m		16,5 m	
		FRONT	LATERAL	FRONT	LATERAL	FRONT	LATERAL	FRONT	LATERAL	FRONT	LATERAL
16,5 m	outriggers down			5,9*	5,9*						
	outriggers up			5,9*	5,9*						
15,0 m	outriggers down					4,5*	4,5*				
	outriggers up					4,5*	4,2				
12,0 m	outriggers down					4,4*	4,4*	3,6*	3,6*		
	outriggers up					4,4*	4,3	3,4	2,7		
9,0 m	outriggers down			6,1*	6,1*	4,6*	4,6*	3,7	3,7		
	outriggers up			6,1*	6,1*	4,6*	4,1	3,4	2,6		
6,0 m	outriggers down	7,2*	7,2*	6,9*	6,9*	4,9*	4,9*	3,8*	3,8*	3*	3*
	outriggers up	7,2*	7,2*	6,9*	6,3	4,8	3,7	3,2	2,4	2,2	1,6
4,5 m	outriggers down	13*	13*	7,3*	7,3*	5*	5*	3,8*	3,8*	2,9*	2,9*
	outriggers up	13*	11,8	7,3*	5,8	4,6	3,5	3	2,3	2,1	1,5
3,0 m	outriggers down	1,7*	1,7*	7,6*	7,6*	5,1*	5,1*	3,8*	3,8*	2,8*	2,8*
	outriggers up	1,7*	1,7*	7	5,2	4,3	3,3	2,9	2,2	2,1	1,5
1,5 m	outriggers down			7,6*	7,6*	5,2*	5,2*	3,8*	3,8*	2,8*	2,8*
	outriggers up			6,4	4,7	4,1	3	2,8	2,1	2	1,4
0 m	outriggers down			7,5*	7,5*	5,1*	5,1*	3,7*	3,7*	2,7*	2,7*
	outriggers up			6,1	4,4	3,9	2,8	2,7	2	2	1,4
-1,5 m	outriggers down			6,9*	6,9*	4,9*	4,9*	3,5*	3,5*		
	outriggers up			5,8	4,1	3,7	2,7	2,6	1,9		
-3,0 m	outriggers down			6,4*	6,4*	4,5*	4,5*	3,2*	3,2*		
	outriggers up			5,7	4	3,7	2,6	2,6	1,8		
-4,5 m	outriggers down			5,6*	5,6*	4,1*	4,1*	2,9*	2,9*		
	outriggers up			5,6*	4	3,6	2,6	2,6	1,8		
-7,5 m	outriggers down					2,5*	2,5*				
	outriggers up					2,5*	2,5*				

The specified max. loading capacities in tonnes include a stability of 33% or are calculated at 87% of the hydraulic lifting power, as per ISO10567. These values are applicable at the tip of the arm with optimum positioning of the corresponding arm system. Weights of attached load carrying accessories (grab, magnet, load hook, etc.) are not included with the load carrying values. \* Value limited due to hydraulics.

[www.atlasgmbh.com](http://www.atlasgmbh.com)

**ATLAS Maschinen GmbH**  
**EXCAVATORS**  
 Atlasstrasse 6  
 27777 Gandersesee, Germany  
 T: +49 (0) 4222 954 0  
 F: +49 (0) 4222 954 343  
 info@atlasgmbh.com

400MH-EN (1) Effective date: March 2012. Product specifications and prices are subject to change without notice or obligation. The photographs and/or drawings in this document are for illustrative purposes only. Refer to the appropriate Operator's Manual for instructions on the proper use of this equipment. Failure to follow the appropriate Operator's Manual when using our equipment or to otherwise act irresponsibly may result in serious injury or death. The only warranty applicable to our equipment is the standard written warranty applicable to the particular product and sale and Atlas makes no other warranty, express or implied. The only warranty applicable to our equipment is the standard written warranty applicable to the particular product and sale and Atlas makes no other warranty, express or implied. Products and services listed may be trademarks, service marks or trade-names of Atlas Maschinen GmbH and/or its subsidiaries. All rights are reserved. Atlas® is a registered trademark of Atlas Maschinen GmbH. Copyright © 2012 Atlas Maschinen GmbH.