

ATLAS KOMPAKT

Excavator AC 20B



Operating Weight	1.94 t (rubber track)
Engine Power	13.3 kW/2200 rpm
Engine Brand	YANMAR
Standard Bucket Capacity	0.04 m ³
Max. Digging Depth	2.38 m

Excavator AC 20B

Parameter

ENGINE	
Brand	YANMAR
Model	3TNV76-SSU
Type	3-cylinder water-cooled indirect injection
Displacement	1.116 L
Power	13.3 kW/2200 rpm

DIMENSIONS	
Counterweight Clearance	482 mm
Tail Swing Radius	1120 mm
Shipping Length	3820 mm
Transport Width	990 mm
Shipping Height	2370 mm

ELECTRIC SYSTEM	
Nominal Voltage	12 V
Batteries	63 Ah
Alternator	12 V-40 A
Starter	12 V-1.4 kW

WORKING RANGES	
Max. Cutting Height	3770 mm
Max. Loading Height	2720 mm
Max. Digging Depth	2380 mm
Max. Vertical Wall Digging Depth	1870 mm
Max. Digging Reach	4040 mm
Max. Reach at Ground Level	3945 mm
Bucket Digging Force	22.7 kN
Stick Digging Force	9.9 kN
Ground Pressure	30 kPa
Swing Speed	10 rpm

DRIVE	
Max. Travel Speed (2nd/1st)	3.5/2.0 km/h
Gradeability	30°
Max. Traction	16.7 kN

UNDERCARRIAGE	
Undercarriage Width	990/1360 mm
Shoe Width	230 mm
Length to Center of Rollers	1210 mm
Track Length	1555 mm
Track Height	385 mm

CAPACITY	
Fuel Tank	23 L
Hydraulic Oil Tank	35 L

BULLDOZING BOARD	
independent moving, controlled by the gear shift lever	
Length X Width	1360x267 mm
Max. Lifting Height	295 mm
Max. Cutting Depth	360 mm

HYDRAULIC SYSTEM	
Main Pumps	
Type	2 variable displacement pumps, 1 gear pump
Displacement	2x21 + 15 L/min
Working Pressure	22.5/18 MPa

Excavator AC 20B

Working Ranges

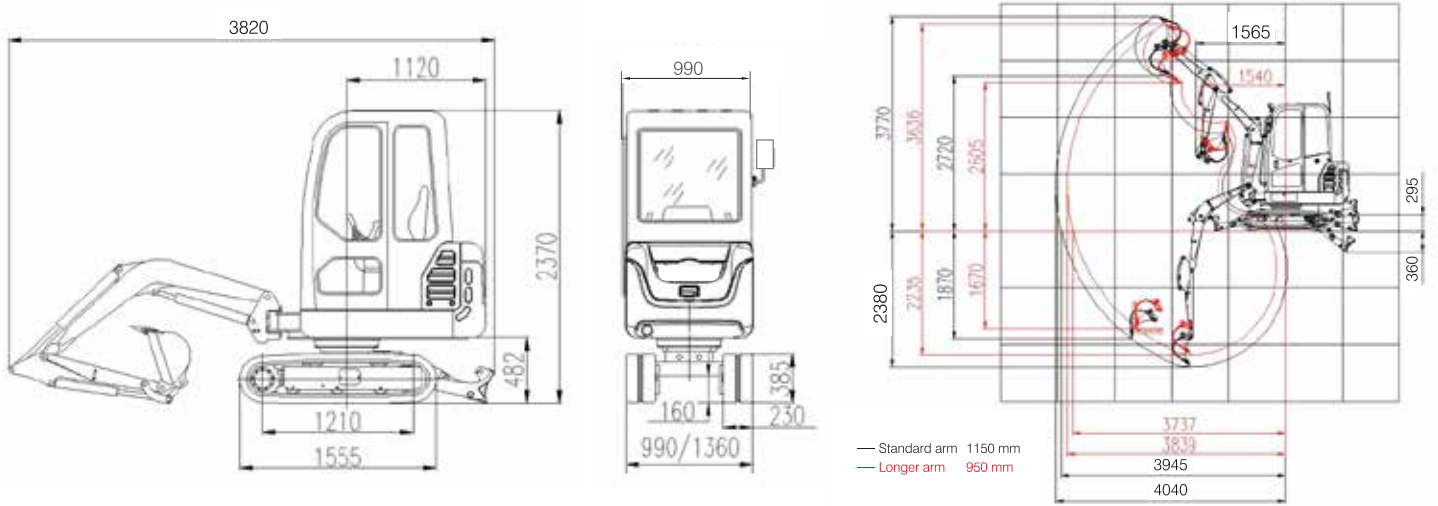

Load Capacity (standard stick: 1.15 m)

A(m) \ B(m)	MAX		3.0 m		2.5 m		2.0 m	
	Front(kg)	Side(kg)	Front(kg)	Side(kg)	Front(kg)	Sides(kg)	Front(kg)	Sides(kg)
2.5	260.00	220.00	—	—	220.00	220.00	—	—
2.0	260.00	180.00	250.00	210.00	240.00	240.00	—	—
1.0	280.00	150.00	310.00	200.00	360.00	270.00	470.00	380.00
0.0	300.00	160.00	360.00	190.00	470.00	250.00	670.00	350.00
-0.5	320.00	170.00	360.00	190.00	480.00	250.00	670.00	340.00
-1.0	330.00	200.00	—	—	440.00	250.00	620.00	340.00

Notes:

- 1) Load with * is limited by hydraulic capacity and based on ISO 10567. Rated loads do not exceed 87% of hydraulic capacity.
- 2) Load without * is limited by tipping load and based on ISO 10567. Rated loads do not exceed 75% of tipping load.

ATLAS KOMPAKT GMBH
 Stedinger Straße 324
 27751 Delmenhorst
 Germany
WWW.ATLAS-KOMPAKT.COM

