

AR 250^e

OPERATING WEIGHT
13,800 kg

ENGINE OUTPUT
160 kW (215 HP)

SHOVEL CAPACITY
2.0 – 4.5 m³



 **Weycor**
BY ATLAS WEYHAUSEN

“

**WE'VE TAKEN IT TO
THE LIMIT AND WE'VE
THOUGHT OUTSIDE THE
USUAL BOUNDARIES –
AND DONE BUSINESS
BEYOND THEM.**

Artur Gabriel, Head of Development & Construction
on the AR 250e



07

TYPICAL WEYCOR!

The flexibility of a medium-sized enterprise and an outstanding team spirit combine to produce stellar results.

09

THE FIRST IMPRESSION

The AR 250e in impressive figures.

12

XXL EQUIPMENT

Six arguments that make our new wheel loaders unique.

14

LIMITLESS

The AR 250e feels at home everywhere, in earthworks and civil engineering, materials handling or extraction.

18

GREAT VIEW

360° all-round view and modern ergonomics to ensure comfort and precision while on the job.



22

BETTER EQUIPPED

The highlights of the AR 250e are impressive!



24

INNOVATIVE!

Powerful hydraulics and the latest control technology for work efficiency.

26

MORE FROM LESS

Best engine performance with low fuel consumption.

28

NUMBERS AND FIGURES

All technical specifications and important data at a glance.





QUALITY AND RELIABILITY. EVEN IN THE XXL SERIES.

The exceptional flexibility of a medium-sized company and the outstanding team spirit which binds our employees as well as our dealers guarantee a high performance potential for our products. "Short and sweet", just how we like it in northern Germany: our organisation is clearly structured, our dealers are involved in our ideas, and decisions get made very quickly. We also benefitted from this intensive cooperation in the lead up to the new wheel loaders

AR 200e and AR 250e. What's more, the opinions of our customers were also very important to us during the development process and had a positive influence on our decisions. The results are impressive: an XXL construction machine that meets the highest requirements in various application areas. The AR 250e – the new power class from Atlas Weyhausen.

1971

Launch of wheel loader production in Wildeshausen

AR 70 is the very first wheel loader to be produced in Wildeshausen in 1971. The identifier "AR" stands for "ATLAS Radlader (wheel loaders)" and has been used by customers and dealers as part of the naming process ever since.

1975

First wheel loader with hydrostatic drive

Hydrostat – the new drive concept – replaces the manual gearbox. A hydrostat is often the optimal type of drive when the continuous adjustment of wheel loader speed is required.

1998

New wheel loader concept

Rethinking wheel loaders: with a new design characterised by rounded shapes and a newly developed workplace, the best all-round vision and ergonomic aspects, we are ready for the future.

2005

Compaction equipment from Wildeshausen

Compaction technology is in world-wide demand. In order to reach new markets, we are introducing single drum rollers and tandem rollers into our range. The construction and production take place in Wildeshausen.

2013

Wheel loaders of the e-generation

The new wheel loader generation with the suffix "e" fulfils all the requirements of the stricter emission guidelines – and even surpasses them! In addition, all e-models enjoy a significant increase in performance.

2016

weycor by Atlas Weyhausen // New XXL wheel loaders

From the ATLAS brand comes weycor. The products from Wildeshausen now have a new brand name. Nothing else has changed!

Atlas Weyhausen revealed the AR 250e for the first time at the bauma 2016. The series was launched in April 2017.



FIRST IMPRESSIONS COUNT!

We think the weycor XXL wheel loader is great. But the AR 250e is on a whole other level! With the AR 250e, you get a power class that offers plenty for every application worldwide. It is tailor-made in every detail for your driver's comfort and work. On top of all this, the engine is extremely strong, leading-edge, environmentally friendly and impressively economical in its consumption.

13,800 ^{KG} OPERATING WEIGHT

160 ^{KW (215 HP)} ENGINE OUTPUT

2.4 ^{M³} STANDARD SHOVEL CAPACITY

Dimensions

Operating weight	13,800 kg
Engine output	160.0 kW
Model	Deutz diesel engine
Design	water-cooled
Max. torque	900 Nm
Cubic capacity	6,057 cm³
Number of cylinders	6 in line
Operating voltage	24 V
Fuel capacity	250 litres

Specifications

Turning radius around shovel edge	5,497 mm
Breakout force	11,900 daN
Thrust	11,600 daN
Tipping load extended	8,616 kg
Tipping load bent	7,854 kg
Operating weight	13,800 kg
Average sound power level L _{WA} ⁽¹⁾	100.0 dB(A)
Guaranteed sound power level L _{WA} ⁽²⁾	101.0 dB(A)
Sound pressure level L _{pA} ⁽³⁾	69.0 dB(A)
Vibration values hand/arm/whole body vibration ⁽⁴⁾	< 2.5/0.5 m/s²

(1) In accordance with 2000/14/EC and Annexes. (2) In accordance with 2000/14/EC and Annexes. (3) In accordance with ISO 6396. (4) In accordance with ISO 8041.

Important information about the shovel capacity:

The information in this brochure refers exclusively to the standard shovel. Depending on the specific density of the material, shovels with different capacities are also available. However, not only must a stability test be carried out taking into account the dead weight of the shovel, the varied forces on the hoisting unit must also be considered. Under certain circumstances, it is entirely possible to use shovels with a different volume. In this matter, please always contact your local dealer.



AN XXL SIZE WITH XXL EQUIPMENT



1

100 % electrically-operated differential lock in front and rear axles

Powerful propulsion and high traction when needed. Wear on tyres is reduced.



2

Work cabin – with maximum all-round visibility

The curved front windscreen, the uninterrupted side window to the right with flush sliding window and the recessed rear windscreen provide an extraordinary all-round view.

The modern ergonomics of the driver's seat and the optimal accessibility of both the display controller and joystick eliminate work fatigue.



3

Most powerful engine and best power to weight ratio in its class

Sensitively tuned 2-stage drive and unique balance between thrust and lifting power. 160 kW (215 HP) offer significant power reserves.



4

Adjustable pulling force limit with 100 % kick-down function – for more power

Adjust the traction force to any substrate via the weycor controller – and go full power at any time using the weycor joystick by pressing the button for maximum push/pull.



5

Separate inch pedal and the drive pedal function – for greater sensitivity

Typical for weycor wheel loaders is the separate inch pedal for the sensitive distribution of thrust and lifting forces. The use of the accelerator as the drive pedal is just as practical. When using the hand throttle, the engine speed is kept constant, however the angle in the drive pump is variable, so the thrust can be finely regulated.



6

Extremely compact dimensions and low profile – for excellent visibility

The total height of an AR 250e with the standard tyre is 3.25 m. The compact design is a continuation of the style from the compact wheel loader series with excellent visibility.



APPLICATION WITHOUT LIMITS

The AR 250e – the “Swiss army knife” of wheel loaders. There are no limits to our new workhorse, from the sandpits to industrial or agricultural use. A mighty engine provides a powerful drive with optimum traction, while the proven and robust weycor kinematics ensure high breakout forces and excellent lifting heights. With the appropriate accessory tool, the AR 250e is at home anywhere.

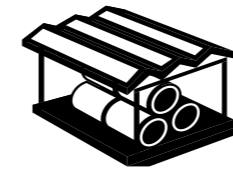

CIVIL ENGINEERING AND EARTHWORK

Loading shovel

For earthmoving work and transporting all kinds of bulk materials.

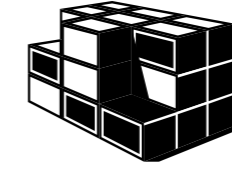

MATERIALS HANDLING

Light cargo shovel

Large volume shovel with or without teeth – depending on the density of the material.

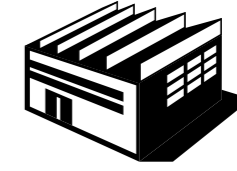

EXTRACTION

Heavy duty shovel

Suitable for heavy cargo and earthwork, generally in a reinforced construction and with wear-resistant shovel blade.

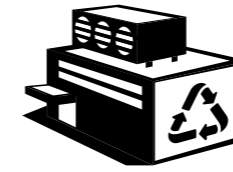

RECYCLING

Shovel with hold-down device

A hydraulic hold-down device is used to secure loose or bulky material in the shovel.

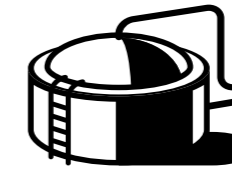

AGRICULTURE AND BIOGAS

Agricultural attachments

Whether you need a bulk material shovel, high-tipping shovel, green forage fork or silo removal technology – versatility is a must in agriculture.

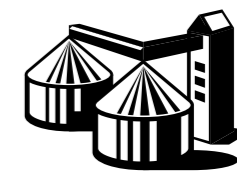

FORESTRY

Logging fork

Suitable for loading logs and timber, generally in a fork or hook design.



GREAT VIEWS FROM THE CABIN

The cabin in the AR 250e is a completely new experience. We ensure a low sound level and a high level of safety as standard.

We also place great importance in optimal 360-degree all-round visibility, so the driver of the AR 250e can always keep their eyes firmly on their work environment.

The display and control elements also provide a good overview: Following an extensive visual field analysis, we ensured the optimal placement of all switches in the cabin, while keeping the display tidy and reduced to the essentials.

The cabin interior is rounded off with a well thought-out ventilation system and ergonomic design. The perfect atmosphere for work!



All-round visibility

The curved front windshield, the uninterrupted side window to the right with flush sliding window and the recessed rear windscreen provide an extraordinary all-round view – for precise work.



Narrow steering column

The steering column occupies only a third of the entire front and ensures seamless control of the shovel movements.



High safety

In addition to the specifications for ROPS, all FOPS Level 2 safety precautions were also included in the construction of the cabin – for maximum safety.



Low sound level

Thanks to good insulation, we have managed to achieve one of the lowest sound levels on the market. All equipment and elements that produce noise and heat are outside the cabin.



Seat comfort to reduce fatigue

The modern ergonomics of the driver's seat and the optimal accessibility of both the display controller and joystick eliminate work fatigue.



Carefully considered ventilation

The air filter placement at the highest, dust-free point of the machine guarantees fresh air in the interior. Additionally, an overpressure in the cabin prevents the entrance of pollutants.

UNIQUE FIELD OF VISION



Front:
Unobstructed view at floor level without steering column blockage



Side and rear:
Perfect all-round vision without the need for a rear-view camera

CAREFULLY CONSIDERED DISPLAY



Display:
Simplified and clear display for ease of operation



Controller:
Variable key fields for driving and working

ADJUSTABLE STEERING WHEEL



Steering wheel:
Individually adjustable in height and angle – the display swivels with

INTUITIVE OPERATION



Control & operating elements:
Reduced elements for intuitive operation, joystick moves ergonomically with the seat and fits any hand size

GENEROUS STORAGE SPACE



Storage options:
Fixed place for Euro boxes – for documents and the driver's private things, ideal for multi-shift operation

MORE FROM LESS

6 cylinder, 215 HP: The AR 250e moves forward with power. Here, too, we've considered far ahead. The goal was to reduce fuel consumption by sustainably increasing the overall efficiency of the engine, for example by reducing the diesel engine speed and including generously designed hydraulic components. Due to the electronically controllable individual components, the components in the AR 250e are capable of communicating.

The diesel engine thus delivers only as much power as is actually required. This reduces consumption, emissions and noise.

The latest kinematics

Tried and tested weycor kinematics with high breakout forces and an excellent lifting height.

Optional hydraulic quick-change mechanism according to ISO 23727

Makes it possible to change the attachment in seconds and turns the wheel loader into a real all-rounder.

Easy servicing

Fast, easy maintenance and upkeep as a result of centrally arranged, easily-accessible service points.

Articulated joint & floating axle

For outstanding off-road capability and manoeuvrability. Unique stability because of the low centre of gravity, even off-road.

Only manufacturer with a separate inching pedal & the drive pedal function

Precise distribution of shearing and lifting forces, along with reduced wear and fuel consumption. Unlike a combined braking /inching pedal, the separate inching pedal eliminates the risk of inadvertently activating the main brake. The use of the accelerator as the drive pedal is just as practical. When using the hand throttle, the engine speed is kept constant, however the angle in the drive pump is variable. Here, again, the thrust force is finely regulated.

Comfortable cabin

Safe, fatigue-free working with excellent all-round visibility, clearly arranged instruments and ergonomic design. Readied additional mounting points for optional accessories.

Powerful drive

Optional traction via 100 % electrically-operated differential lock in front and rear axles.

Unique engine mount

Independent suspension of the engine decoupled from the axle to avoid vibration and noise emission.



INNOVATIVE HYDRAULICS CONCEPT

Power to perform

The hydraulics concept was developed and carefully coordinated with Bosch Rexroth. Powerful hydraulics and extreme user-friendliness position the new weycor large wheel loader as a front-runner amongst high-performance loaders of this size.

Flexible working hydraulics

Designed for fast movement at low speeds – the latest control valve technology and high forces ensure efficient work.

Fan drive

On-demand fan drive allows reduced emissions and fuel savings, even at outdoor temperatures of up to 50 °C.

Individual settings

The weycor display control system and quick-access buttons offer the driver a wide range of possible setting options, including diesel engine speed, flow rate and continuous operation.

Drive

Powerful hydrostatic drive with fine dosing allows working in confined space without using the brake. The drive is optimally tuned to the diesel engine and runs steplessly up to 40 km/h with two drive engines. Both engines are operated up to 14 km/h. After that, the engine with the larger volume is swivelled into the zero position and the complete oil flow is made available only to the second engine with the smaller volume. Thermal problems are thus avoided. In addition, different driving modes (optional) can be set.

Charge mode

Maximum performance at up to 2000 rpm, high speed of work functions and dynamic acceleration and deceleration enable high handling performance.

Pallet mode

Thanks to the high engine speed in this driving mode, the machine is also able to accelerate and decelerate smoothly when the driver needs to drive delicately. This mode can also be used for shovel operation.

ECO mode

The engine speed is limited to 1650 rpm, but almost all the power (145 kW/200 HP) is available. Fuel-efficient working and road travel at full speed are possible.

Pulling force limit

Reduction of the pulling force to adapt to different substrates and to minimise tyre wear. Via the kick-down button on the joystick, the limit can be overridden at any time with 100 % power for a short period.

Speed limit

Limit the maximum speed for certain applications – regardless of the driving mode.

Hand throttle

Pre-selectable engine speed for applications such as snow ploughing, etc. The accelerator pedal serves as the drive pedal in this case and determines the speed of the machine.

Cruise control

Relieve the driver during longer journeys at a constant speed.

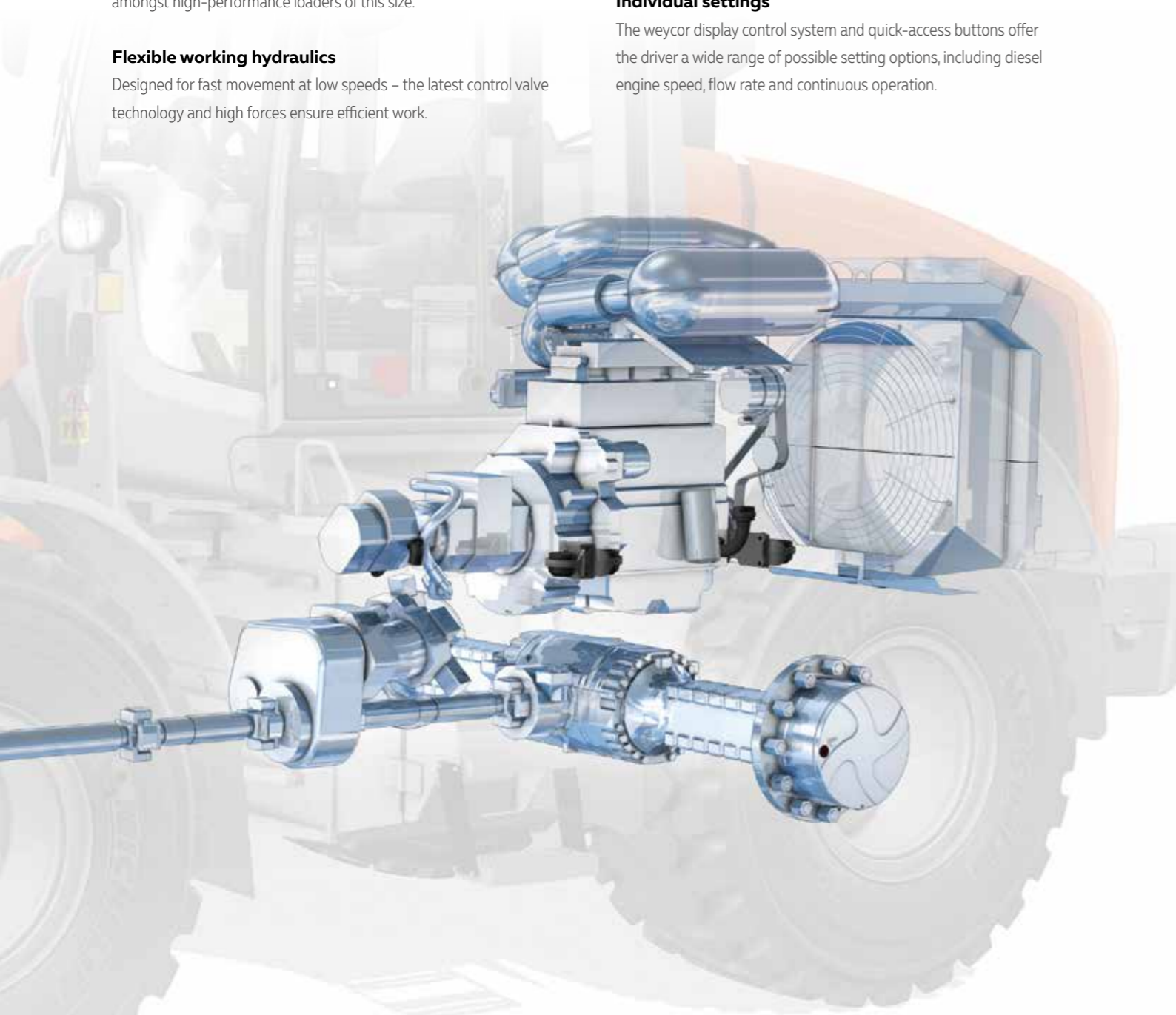

INNOVATIVE ENGINE TECHNOLOGY

TCD 6.1 L6 – intelligent and efficient:

We have been convinced of the quality of Deutz engines for over 40 years. Our cooperation with Deutz also offers numerous benefits for the AR 250e: such as the electronic engine control with intelligent connection to the drive management. This ensures the best engine performance with low fuel consumption. The water-cooled TCD 6.1 L6 diesel engine is at the heart of our new power class.

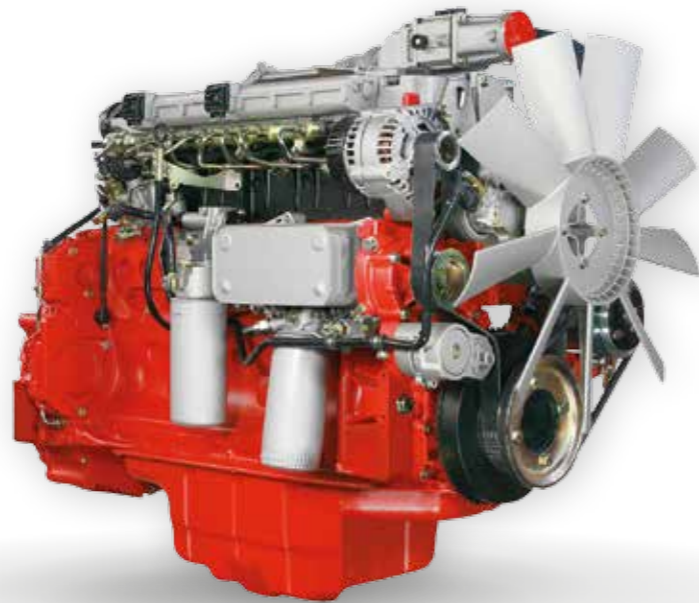

Mighty performance

160 kW at a maximum of 2000 rpm

Compliance with emission standards

Thanks to the exhaust system used, the engine complies with DOC/DPF/SCR TIER IV final and is TIER V ready.

Deutz engine technology: TCD 6.1 L6

Water-cooled 6 cylinder in-line engine with turbocharging, intercooling and cooled external exhaust gas recirculation.

The powerful Deutz Common Rail (DCR®) injection system and the electronic motor control (EMR 4) with intelligent connection to the drive management ensure the best engine performance with low fuel consumption. The engines meet the requirements of the EU Stage IV and US EPA Tier 4 standards with DVERT® selective catalytic reduction (SCR) and particle filter (DPF).

With the use of the DPF, they are already compliant with the EU Stage V emission standard expected from 2019.

HIGH ENGINE POWER – AT LOW ENGINE SPEED

Engine power curve

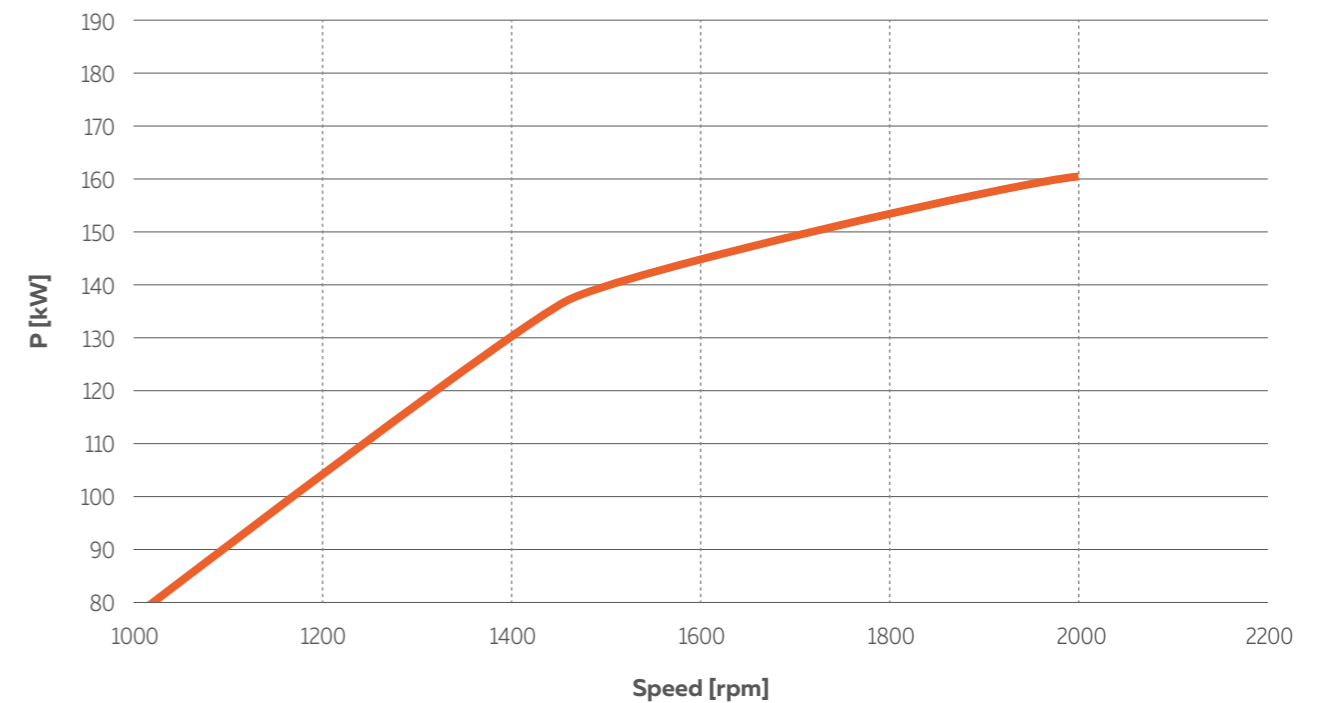

ECO mode

For light work and road travel, 40 km/h is reached at 1650 rpm. Maximum of 145 kW available.

Powerful fan drive with optional fan reversal for quick cleaning

Fan drive with electronic control and optimum efficiency in every speed range thanks to a generously sized variable displacement pump.

Full fan performance is also available in Eco mode.

TECHNICAL DATA

Engine	
Model	Deutz TD 6.1 L6 diesel engine
Design	water-cooled
Output***	160 kW (215 HP) at 2,000 rpm
Max. torque	900 Nm at 1,450 rpm
Cubic capacity	6,057 cm ³
Number of cylinders	6 in line

Electrical system	
Operating voltage	24 V
Battery	24 V / 100 Ah
Generator	24 V / 100 A
Starter	24 V / 4 kW

Drive	
Maximum load-regulated, hydrostatic drive with pressure cut-off and closed circuit, acting on all 4 wheels. Speed ranges apply to standard tyres:	
Operation	0-14 km/h
Fast speed	40 km/h
Shifting between 1st and 2nd hydraulic gear and between forward and reverse movement possible while under load. Control of forward/reverse movement and drive levels using weycor joystick. Control of the drive system using the drive pedal and a separate inching pedal for optimal distribution of the hydraulic power to thrust and lifting forces.	

Braking	
Operating brake: Oil bath multi-disc brake, acting on all 4 wheels. Supplementary brake function via the inching pedal and hydrostatic drive, acting on all 4 wheels.	
Parking brake: Negative brake in spring-loaded design, acting on all 4 wheels. When the engine is stopped, the spring-loaded brake is activated.	

Steering	
Fully hydraulic central articulated steering and rear floating axle	
Front and rear wheels run on one track	
40° articulation angle both sides	
Articulation angle ±12° at rear of vehicle	

Tyres	
Standard: 20.5 R 25 – construction machine tyres for use on relatively soft ground with high traction and good self-cleaning	

Hydraulics	
Variable displacement pump for loading and steering hydraulics	
Priority valve prioritises steering	
The 1st and 2nd control circuit are standard	
Loading hydraulics hydraulically operated, controlled by weycor joystick, including lockable float position	
Operating pressure 280 bar, flow rate 190 l/min	

Capacities	
Fuel	250 litres
Hydraulic oil	140 litres
Engine oil	16 litres
Front axle	19.2 litres
Rear axle	19.2 litres
Gearbox	3.5 litres
Coolant	35 litres
AdBlue	20 litres

Loading equipment	
Powerful and solid Z-kinematics with high breakout force	
Operation of all functions via weycor joystick	
Parallel guide for pallet fork operation via optional electrical control	
Automatic shovel return to digging position	
Locking for road travel in accordance with StVZO (German Highway Code)	

Lifting	5.9 s
Lowering	4.4 s
Tipping	1.8 s

Equipment	series	option
Weycor diagnostic system (ADS) for monitoring the machine parameters	•	
Foldable exterior rear-view mirror	•	
Heated rear windshield	•	
Single lever operation via weycor joystick	•	
Driving range display, forward/reverse travel	•	
Vehicle lighting acc. to StVZO (German Highway Code)	•	
Individually adjustable driver's seat with adjustable right armrest	•	
Water heating with heat exchanger and 3-speed fan	•	
Air conditioning	•	
Adjustable front windscreen ventilation	•	
Soundproofed ROPS cabin	•	
Front and rear working headlights	•	
Windshield wiper and washer system front and rear	•	
Sun visor, coat hook, interior light, storage space	•	
Steplessly adjustable and telescopic steering column	•	
Heat-proofed panoramic glass panes	•	
Warning lights for engine oil pressure, engine overheat, hydraulic oil temperature, battery charging, parking brake, air filter monitoring	•	
Central dashboard with indicators for pre-warming, engine temperature, fuel supply, operating hours counter	•	
Main battery switch	•	
Lifting arm damping		•
20 km/h limitation		•
Trailer coupling		•
Special coatings		•
All-round lighting		•

Equipment	series	option
Heated driver's seat		•
Automatic climate control		•
Radio	•	
Right sliding window	•	
Left sliding window		•
3rd and 4th section, max. 170 l/min		•
Quick-change device that meets ISO 23727		•
Return-to-dig		•
Engine pre-warming		•
Protection grille fans		•
Steel mud guard		•

TECHNICAL DATA

	Without quick-change device standard shovel	With quick-change device and standard shovel	With quick-change device and pallet fork
Tyres (D=1486)	20.5 25 XHA2	20.5 25 XHA2	20.5 25 XHA2
A	7,474 mm	7,732 mm	8,090 mm
B	3,260 mm	3,260 mm	3,260 mm
C	5,340 mm	5,510 mm	4,649 mm
C1	3,936 mm	3,936 mm	3,940 mm
C2 (45°)	2,888 mm	2,704 mm	1,831 mm
D	100 mm	100 mm	0 mm
E (45°)	1,006 mm	1,167 mm	809 mm
E1	-	-	1,683 mm
E2	-	-	1,013 mm
F	401 mm	401 mm	401 mm
G	3,000 mm	3,000 mm	3,000 mm
H	2,490 mm	2,490 mm	2,490 mm
I	2,530 mm	2,530 mm	2,060 mm
K	-	-	1,756 mm
L	1,924 mm	1,924 mm	1,924 mm
M	1,216 mm	1,456 mm	-
N	-	-	1,400 mm (fork length)
R	3,100 mm	3,100 mm	3,100 mm
R1	5,857 mm	5,857 mm	5,857 mm
R2	6,100 mm	6,100 mm	6,100 mm
W	6,258 mm	6,258 mm	6,258 mm
Y	3,670 mm	3,652 mm	-
Z	-	-	2,356 mm
α	40°	40°	-
β	30°	30°	-
γ	43°	43°	-
χ	46°	46°	-
Tipping angle	46.3°	46°	-
Tipping angle below	44.8°	45.3°	31°
Tipping angle transport	47.1°	46.9°	35°
Tipping angle above	49.3°	49.6°	38°

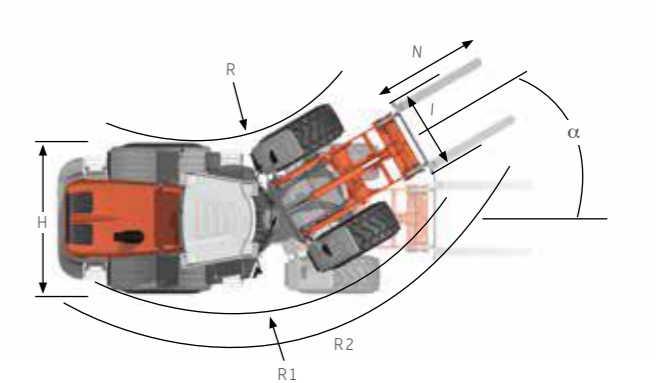
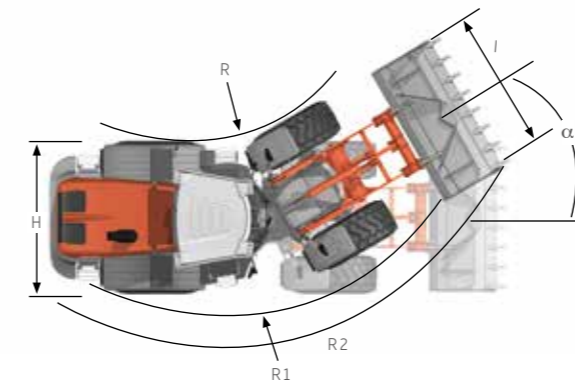
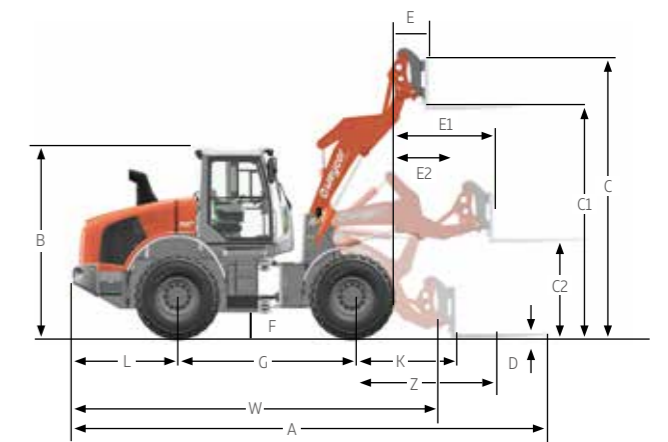
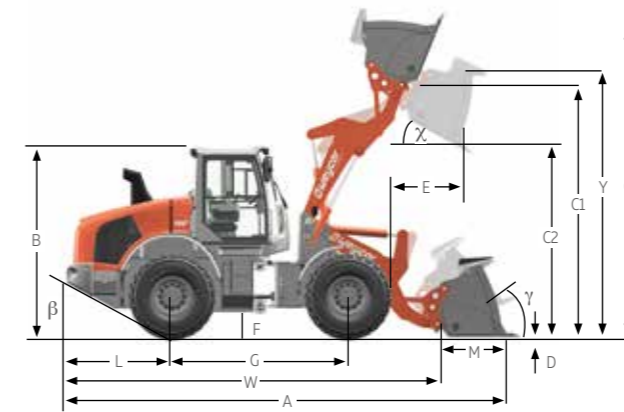

With quick-change device standard shovel

With quick-change device pallet fork 1,400 mm

TECHNICAL DATA

Model standard features	Tipping load	Shovel capacity (100 % fill factor)
With quick-change device standard shovel (+ 330 kg)	7,957 kg	2.2 m ³
Without quick-change device standard shovel	8,616 kg	2.4 m ³

Model standard equipment + additional weight (+ 250 kg)	Tipping load	Shovel capacity (100 % fill factor)
With quick-change device standard shovel (+ 330 kg)	8,285 kg	2.3 m ³
Without quick-change device standard shovel	8,966 kg	2.5 m ³

Model with pallet fork 7 t	Tipping load	Load capacity 60 %	Load capacity 80 %
Model standard features	6,320 kg	3,832 kg	5,110 kg ⁽¹⁾
Model standard equipment + additional weight (+ 250 kg)	6,573 kg	3,986 kg	5,314 kg ⁽¹⁾

(1) When using the default pallet fork.

Table of specific weights in t/m³

Construction industry				Industry		Landscaping, agriculture	
Concrete	1.9	Sand (wet)	2.1	Ash	0.7	Crop (corn, beet)	0.7
Earth (dry)	1.5	Sandstone	2.4	Lignite briquette	0.8	Grain	0.6
Earth (wet)	2.0	Slate	2.2	Iron	7.8	Hay	0.3
Rock (broken)	2.4	Sludge	2.1	Iron ore	2.3	Potash	1.1
Granite	1.8	Rubble	1.5	Broken glass	1.9	Compost	1.0
Limestone	1.6	Road salt	1.3	Gas coke	0.4	Flour	0.5
Gravel (dry)	1.9	Clay	1.6	Wood	0.8	Marl (wet)	2.3
Gravel (wet)	2.1	Cement	1.7	Coal	1.2	Thomas slag	2.2
Loam	1.7	Brick (stacked)	1.8	Paper	0.9	Peat (wet)	1.1
Mortar	2.2			Slag (sand)	1.0	Peat (dry)	0.4
Sand (dry)	1.9			Slag (solid)	2.7	Complete fertiliser	1.0

Shovel selection table

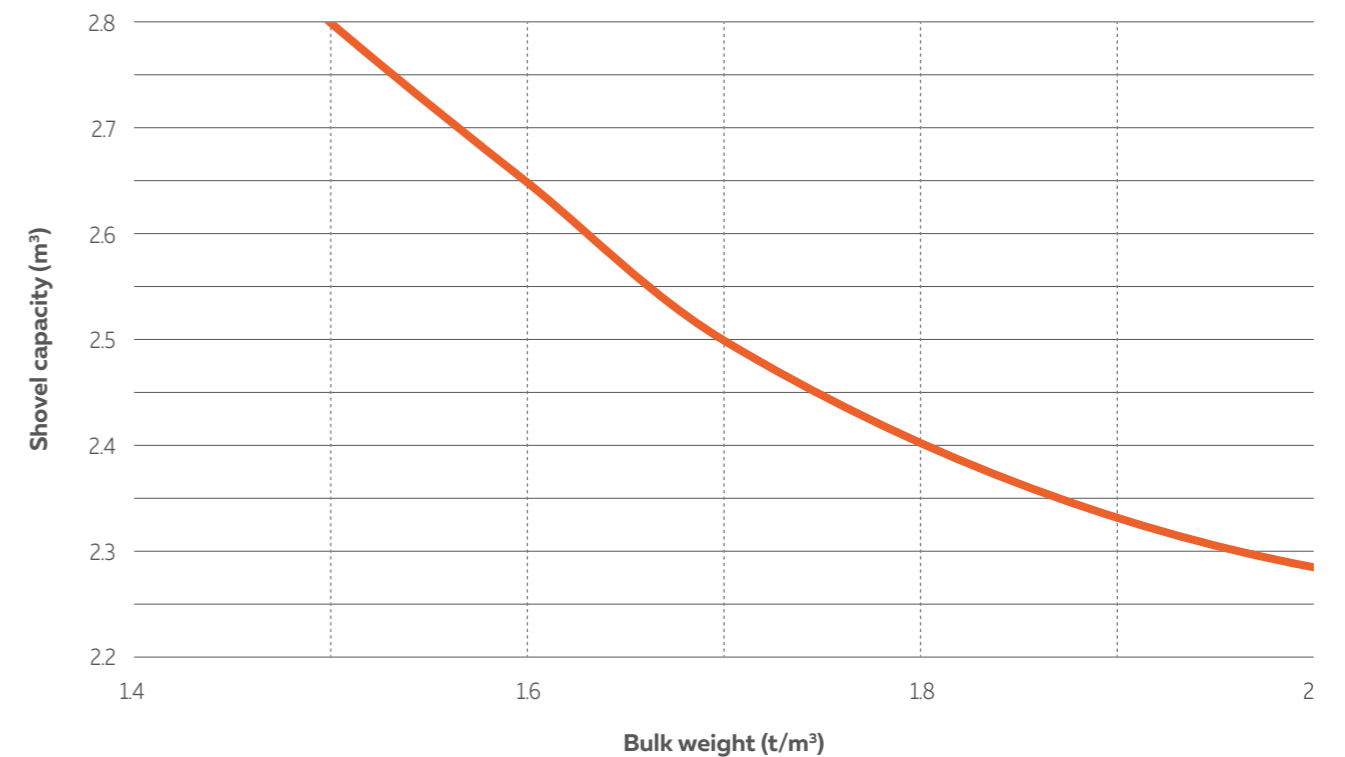

Under our policy of continuous improvement, we reserve the right to change specifications and design without prior notice, errors expected. The technical data refer only to the standard version, illustrations do not necessarily show the standard version of the machine.





You can find our current product range and more exciting details at: www.products.weycor.de

weycor is a brand of ATLAS WEYHAUSEN GMBH.

ATLAS WEYHAUSEN GMBH · D - 27793 Wildeshausen
Phone +49 (0) 44 31 - 98 10 · info@weycor.de · www.weycor.de

 **weycor**
BY ATLAS WEYHAUSEN